

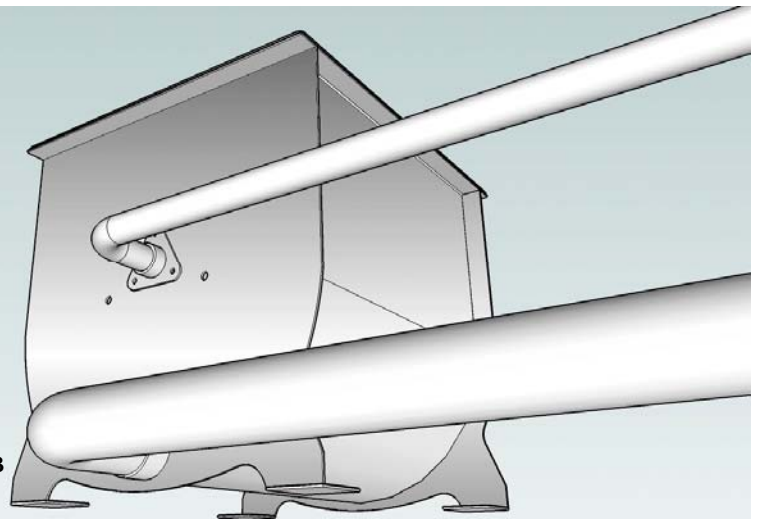

## LINCOLN METER COMPANY

P.O. BOX 64  
WACONIA, MN 55387

PHONE 800-876-9633  
FAX: 952-556-9473



The meter case, metering drum, bearing brackets, bearing wheels, and inlet spout shall be made of stainless steel. A rotating, cylindrical drum of six scroll-shaped chambers measures the liquid by volume. Each compartment shall have two interior baffles attached to the side walls/heads of the drum to form a watertight seal where the baffle and wall meet.

The meter shall be equipped with a PulsePro Totalizer consisting of a remote LCD (lithium battery powered; no external power is required) pre-wired with twenty feet of four conductor cable to a magnetic sensor switch mounted on the meter. A second switch shall be factory installed for connection to the building energy management system. The switch rating is 0.5 amps @ 200 VDC with a square pulse signal.

The meter shall be self-priming at low flow and guaranteed accurate to within plus or minus 1% from low flow to full rated capacity. A certificate, identifying the meter by serial number shall be provided stating capacity and flow test results achieved by actual flow testing using a certified scale. Mathematical calculations of capacity are not acceptable.

Lincoln Model G Flowmeter:  
Part # LM-G160-PR2  
16,000 lbs/hr condensate @ 140°F  
160 lbs per pulse output

1-1/2" NPT Inlet  
4" NPT outlet  
Reed Switch rated at 0.5 amps @ 200 VDC  
Net Shipping Weight: 320 lbs

